

Reg. No. :

Question Paper Code : 60032

B.E./B.Tech. DEGREE EXAMINATIONS, APRIL/MAY 2022.

Second Semester

Electronics and Communication Engineering

EC 3251 — CIRCUIT ANALYSIS

(Common to : Electronics and Telecommunication Engineering)

(Regulations 2021)

Time : Three hours

Maximum : 100 marks

Answer ALL questions.

PART A — (10 × 2 = 20 marks)

1. Ten coulombs of charge flow past a given point in a wire in 2s. How many amperes of current is flowing?
2. Define active and passive elements and give examples.
3. State Maximum power transfer theorem.
4. Draw the dual of the network shown in Figure 1

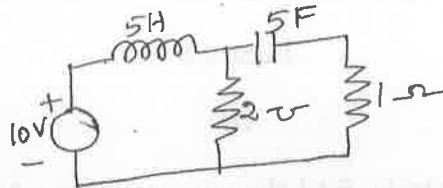

Figure 1

5. Determine the average power delivered to the circuit consisting of an impedance $z = (5 + j8)\Omega$ when the current flowing through the circuit is $I = 5\sqrt{30}$ Amps.
6. For the circuit shown in Figure 2, find the average power delivered by the dependent current source.

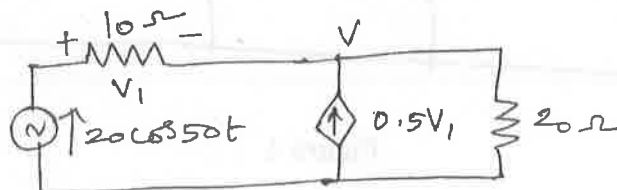

Figure 2

7. Write the mathematical expression for unit step function and draw the pattern of it.
8. Determine the Quality factor of a coil for the series circuit consisting of $R = 10\Omega$, $L = 0.1\text{H}$ and $C = 10\ \mu\text{F}$.
9. Two inductively coupled coils have self inductances $L_1 = 50\ \text{mH}$ and $L_2 = 200\ \text{mH}$. If the co-efficient of coupling is 0.5, find the value of mutual inductance between the coils.
10. List out the properties of tree of a graph.

PART B — (5 × 13 = 65 marks)

11. (a) Using mesh analysis determine the voltage V_s which given a voltage of 50 V across the 10Ω resistor as shown in Figure 3

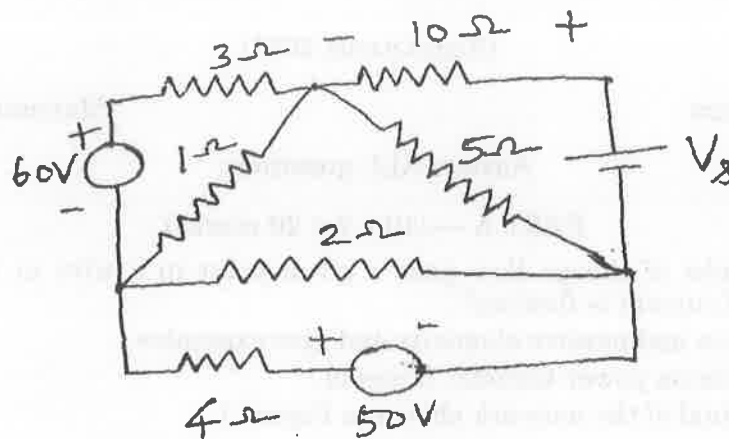

Figure 3

Or

- (b) Using nodal analysis, find the currents through the resistances R_3 and R_4 for the circuit shown in Figure 4

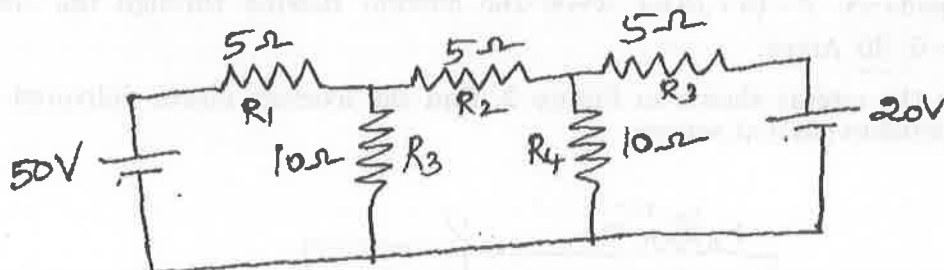

Figure 4

12. (a) Find the voltage across the 2Ω resistor shown in Figure 5 using superposition theorem.

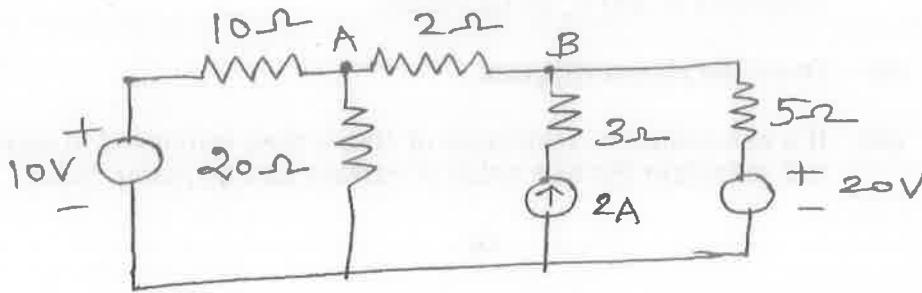

Figure 5

Or

- (b) (i) Determine the resistance between nodes A and B in the circuit shown in Figure 6 (8)

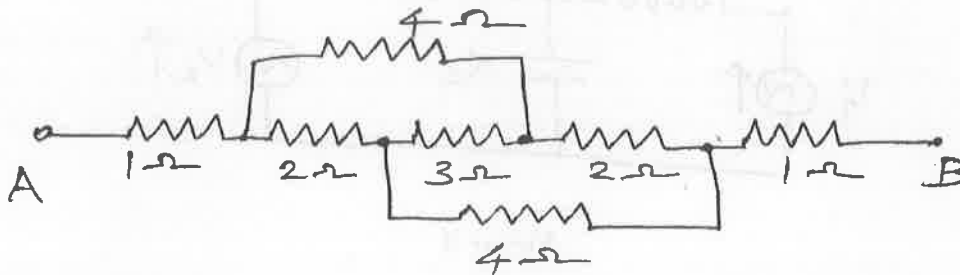

Figure 6

- (ii) Consider the bridge circuit shown in Figure 7. Determine the resistance between nodes A and B and the current supplied by the 24V supply. (8)

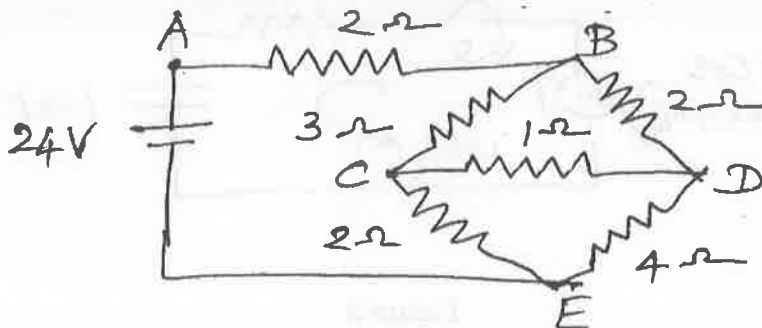

Figure 7

13. (a) A coil has a resistance of 5Ω and an inductance of 31.8 mH .
- Calculate the current taken by the coil and power factor when connected to 200 V , 50 Hz supply.
 - Draw the phasor diagram.
 - If a non-inductive resistance of 10Ω is then connected in series with coil, calculate the new value of current and its power factor.

Or

- (b) The data for the two mesh circuit are

$$V_1 = 110 \angle 0^\circ \text{ V and } V_2 = -120 \angle 45^\circ \text{ V, } R = 4\Omega, X_L = 4\Omega, X_C = 3\Omega$$

Determine the current through and voltage across the capacitance

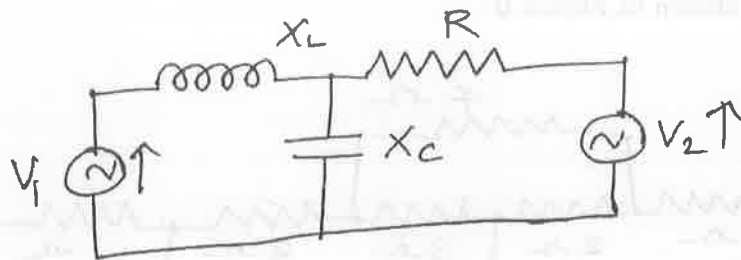

Figure 8

14. (a) In the circuit shown in Figure 9, determine the complete solution for the current when the switch S is closed at $t=0$. Applied voltage is $v(t) = 50 \cos\left(10^2 t + \frac{\pi}{4}\right)$ volts, Resistance $R = 10\Omega$ and capacitance $C = 1\mu\text{F}$.

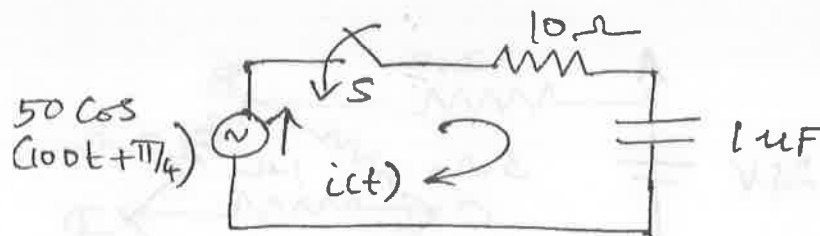

Figure 9

Or

- (b) (i) Find the value of L at which the circuit resonates at a frequency of 1000 rad/sec in the circuit shown in Figure 10. (10)

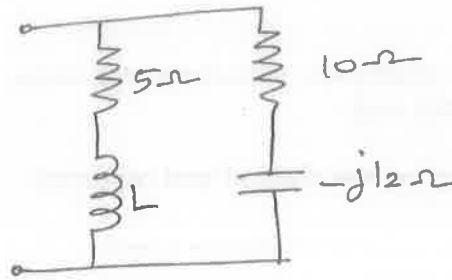

Figure 10

- (ii) Explain parallel resonance and derive the resonance frequency. (6)
15. (a) With relevant diagrams explain the characteristics of an ideal transformer.

Or

- (b) For the electrical network shown in Figure 11, draw its topological graph and any four possible trees.

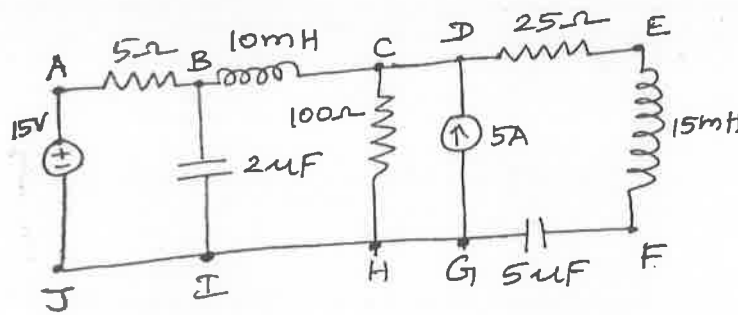

Figure 11

PART C — (1 × 15 = 15 marks)

16. (a) A resistance of 100Ω is connected in series with a $50 \mu F$ capacitor. When the supply voltage is $200V, 50 \text{ Hz}$, find the
- Impedance, current and power factor
 - The voltage across the resistor and across capacitor. Draw the phasor diagram.

Or

- (b) A coil of resistance 10Ω and inductance 0.1 H is connected in series with $150\ \mu\text{F}$ capacitor across 200V , 50 Hz supply.

Calculate :

- (i) Inductive reactance; capacitive reactance, impedance, current and power factor and
- (ii) The voltage across the coil and capacitor.

